

Cloud™ Suspended decorative baffle



PRODUCT OVERVIEW

Dbsorb Cloud™ range of suspended baffle installations create a modern aesthetic with excellent acoustic performance. The Cloud installations are designed to effectively reduce reverberation across a broad range of frequency.

Our Cloud baffle includes an adjustable suspension kit, requiring minimal assembly for installation that allows it to be suspended at a range of heights.

The Cloud baffle can be used to mask services above, as a cloud-like feature in open spaces, or to effectively position over large desks and work spaces.

APPLICATIONS

Ceiling & Wall:
Office Interiors, Showrooms, Hospitality, Education and Residential.



Composition:
100% PET (up to 60% recycled content)



Fire rating 12mm:
EN 13501-1:2018: B - s1, d0



No loose fibres



Antibacterial



Environmental:
Global Recycled Standard (GRS) 4.0
OEKO-TEX® Confidence In Textiles – STANDARD 100
Tested for harmful substances Annex 6"
Low VOC

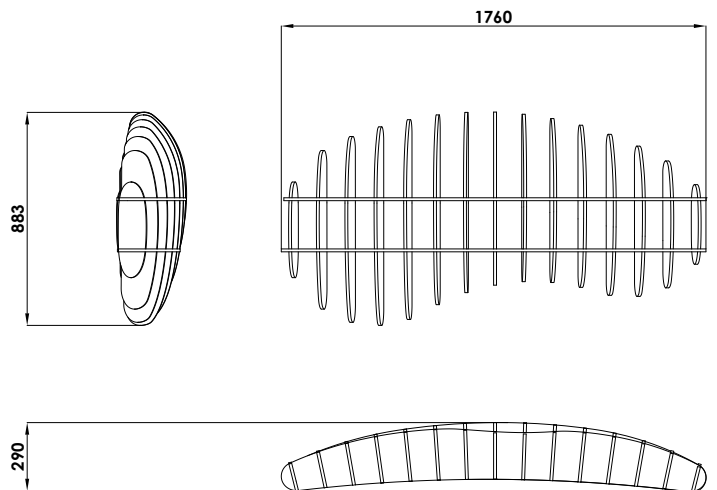

DBSORB Ltd

Acoustic Systems

www.dbsorb.co.nz

Phone: (+64) 09 553 6775

Copyright © 2022 DBSORB Ltd

Email: sales@dbsorb.co.nz

All Rights Reserved

Address: 63S Hugo Johnston Drive, Penrose
Auckland 1061

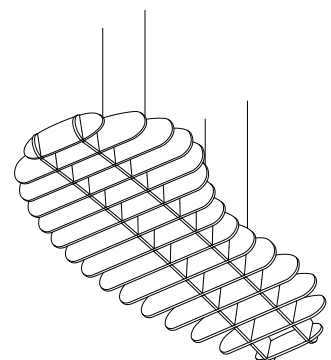

a solution for every space.



dbsorb

acoustic systems