

METALWORKS™ F-PLANK (Interior Applications)

Assembly and Installation Instructions

1. GENERAL

1.1 Product Description

METALWORKS F-Plank is a linear metal ceiling system. F-Plank panels are available 2400mm long and in 100mm, 200mm and 300mm widths, including a 20mm panel flange that can optionally be covered with a black filler strip to create the Contrasts visual. F-Plank panels are made of 0.6 Gauge electro-galvanized steel. Their post-production powder-coated finish is available in white, silver grey and a wide range of custom colours. Microperforated options with a plain border, acoustical fleece backing.

The carrier channel is hung with 5mm Rod. Carriers are hung on 1200mm centers.

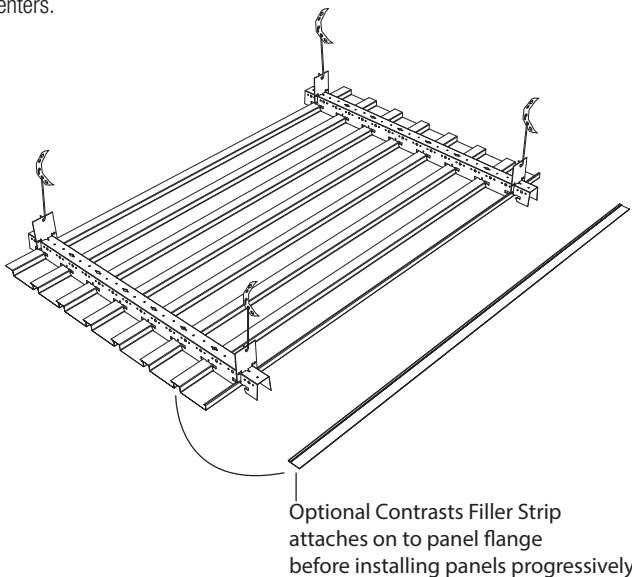

1.2 Storage and Handling

The F-Plank shall be stored in a dry interior location and shall remain in cartons prior to installation to avoid damage. The cartons shall be stored in accordance with the instructions on the carton. Proper care should be taken when handling to avoid damage or soiling.

1.3 Site Conditions

Building areas to receive ceilings shall be free of construction dust and debris.

1.4 Ceiling Panel Layout

The F-Plank layout should have perimeter panels equal in width on opposite ends. These cut perimeter panels should be more than 50% of their original width. See METALWORKS cutting instructions. Divide the room dimension by the nominal width of the panel (100mm, 200mm or 300mm). Determine the remainder, add one full panel width, and divide by two to determine the width of the border panel.

Example: 200mm nominal panel width, room dimension 3100mm. Divide 3100mm by 200mm = 15 full sections with 100mm remainder. Add 100mm + 200mm = 300mm. Divided by 2 = 150mm border panel with 14 full rows of panels. This will create the best visual and installation.

2. PREPARATION

2.1 Determine desired height of new ceiling.

2.2 Strike a level line around the perimeter of the area at this height.

2.3 Determine direction of F-Plank ceiling.

2.4 The carriers will be installed 1200mm on center perpendicular to this direction. The first and last carrier must be within 600mm of the wall.

3. INSTALLATION

3.1 Install the "E" Wall Moulding on the perimeter walls. The "E" Wall Moulding is nominal 50mm high and should be secured to wall at a maximum of 450mm. The bottom of the moulding is the finish height of the F-Plank panel.

3.2 Secure 5mm rods to the structure above to support the carriers. The first suspension point for carriers should be within 300mm of the perimeter and then 1200mm on center.

3.3 Stretch a string line or set a laser at the bottom of the moulding from one side to the other along a row of hanger rods with SCPF, 100mm above finished ceiling height.

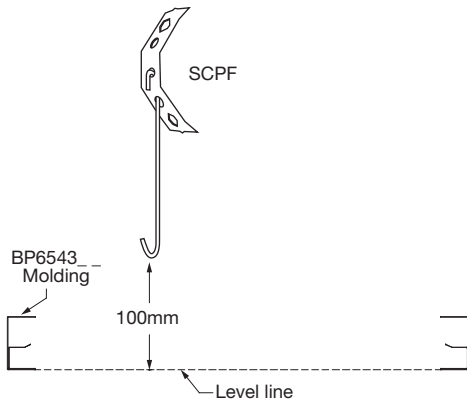

3.4 Hang a Carrier Hanger (item BP5580M) from hanger rods SCPF.

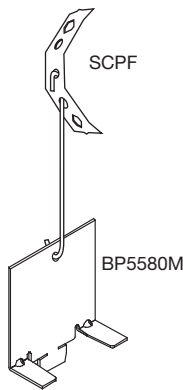

3.5 Stretch a string from one side of the room to the other at the top of the moulding (string perpendicular to carrier). The string should be out from the "end" wall by the calculated width of the first "plank." See section 1.4 for border panel layout.

3.6 Measure from this string to the wall. Cut the first carrier channel in each row so the indicated notch lines up with this string.

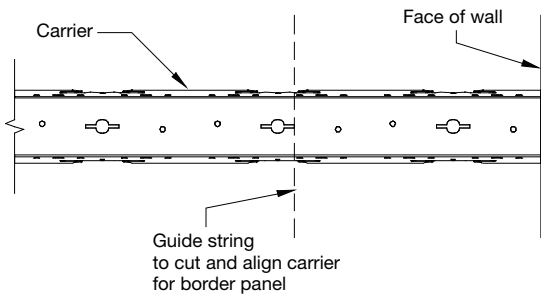

3.7 Secure the carriers to the carrier hangers. Insert the hanger clip into the pre-punched slot on top of the carrier and twist the clip 90 degrees. Bend both side tabs down to lock the clip onto the carrier.

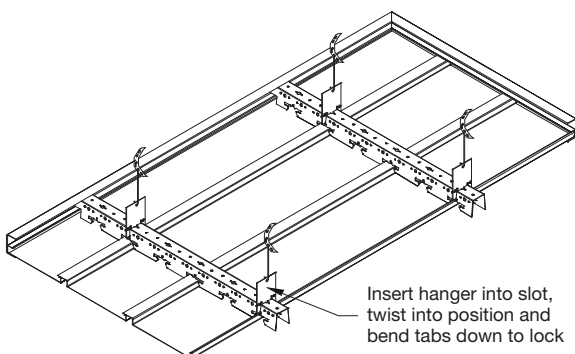

3.8 Fasten the carrier to the moulding at the proper location, align the notch as indicated in Section 3.6 and fasten with a framing screw or pop rivet. Notch the carrier to fit into the wall moulding as needed.

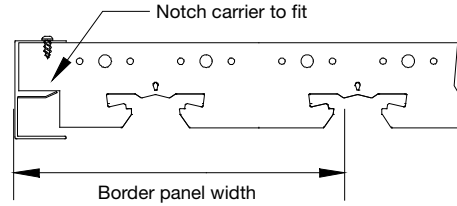

3.9 Use the Carrier Splice (item BP5499M) to join sections of carrier together and maintain the proper spacing. Fit the splice over the top of the carrier. Line up all the holes and insert four framing screws or pop rivets (one on each side and at both ends of the carriers) to secure the splice to the carriers.

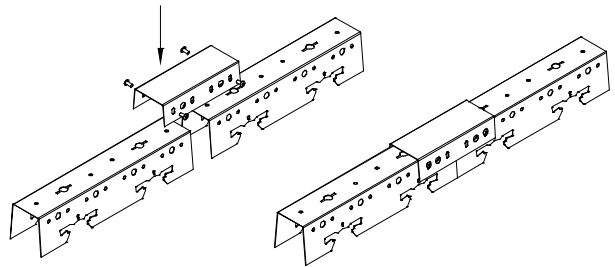

3.10 Complete the run of carriers to the other end of the space.

3.11 Measure from the wall to the string several places and determine the exact width of the first row of panels.

3.12 Mark the plank and cut to width with electric shears. The flange edge is the edge that should be cut off.

3.13 Slide the cut edge of this plank into the perimeter wall moulding.

3.14 The opposite hook edge (factory edge) of the plank will fit onto the tab on the carrier.

3.15 Insert pressure springs or pop rivet panel to secure the panel to the moulding.

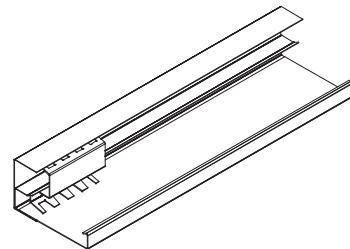
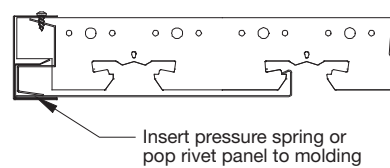

3.16 Cut the panels to length to fit into the perimeter moulding at the sides, parallel to the carrier. Cut end will fit into the lower channel. Use pressure springs on ends as needed.

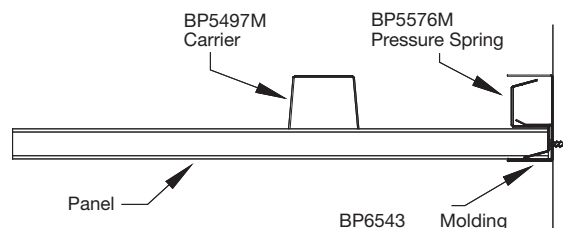

3.17 Panels have a factory return on the ends and have two options to splice the panels when they do not reach across the space in one piece. Install panels so the factory joint is tight and use vise grip pliers to temporarily hold together.

Option 1 – Insert speed clips (BP6351M) over the two panel returns. Use one hand to support the panel face and the other hand to snap the speed clip on the returns. Two speed clips required at each joint.

Option 2 – Insert sheet metal framing screws through the panel returns. This requires a clear plenum to work with power tools above the panel. Two screws required at each joint.

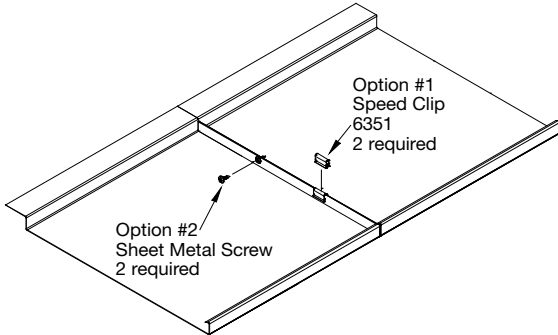

Note: Ends of installed panels will always be visible with this system.

3.18 Install the second row of panels by inserting the flange edge on top of the previous panel. Next, gently push the panel hook side up until it snaps onto the carrier tab.

3.19 Continue installing panels until you reach the other side of the room.

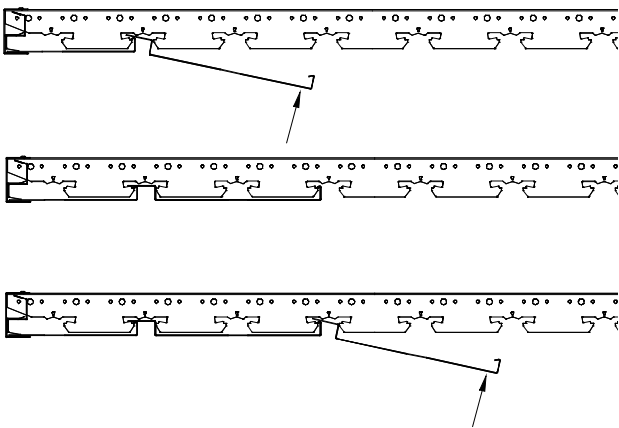

3.20 Do not install the last full panel at this time. Cut the last row border panel to width and insert the long cut edge into the moulding above the bottom flange. Make sure the panel is against the carrier tab for proper alignment. Insert pressure springs or pop rivets to secure the border panel to the moulding.

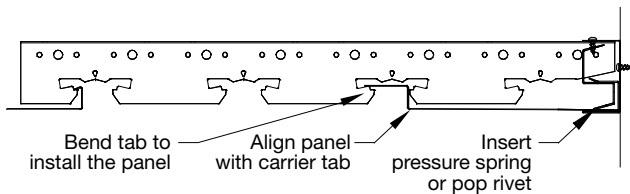

3.21 The last full row of 100mm or 200mm panels must be joined end-to-end after installation, but must be prepared before installation (for 300mm panels see 3.21.8).

3.21.1 Pop-riev a short section of metal angle to the flange of the first panel to be installed in the last row, as shown in the drawing below. This is the end of the panel that does not rest on the wall moulding.

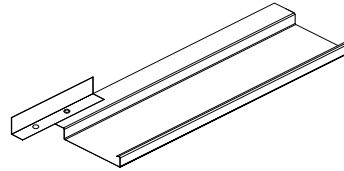

3.21.2 Align another section of the plank with the end of the one just prepared and drill or punch a hole for the pop-riev in the second panel of the row, but do not install the rivet.

3.21.3 Install the first panel in the ceiling by inserting the flange edge on top of the previous panel. Next gently push the panel hook side up until it snaps onto the carrier tab.

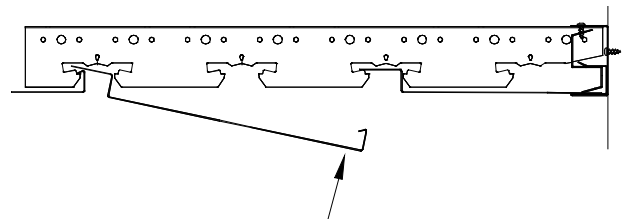

3.21.4 Prepare the third panel in the row as described in section 3.21.1 and 3.21.2 above. Install the second panel in the row and insert the pop-riev in the holes prepared in section 3.21.2.

3.21.5 Continue this pattern for the remainder of the row.

3.21.6 Color the exposed rivets to match the panel finish.

3.21.7 Installing the last row of full 300mm panels. Cut the first panel to length so the end return will be at the middle of a carrier channel. Install the panel flange edge as normal and then gently push the panel hook side up until it snaps onto the carrier tab. Carriers are installed on 1200mm centers, the remaining panel joints should be at carrier channel.

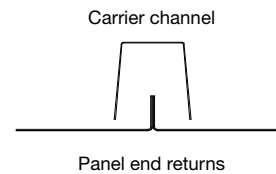

3.22 Optional Contrasts Fillers

Nominal 30mm wide black Contrasts filler strips are field applied to panels before installation. Slide the filler hem over the panel flange. Install panel as normal.

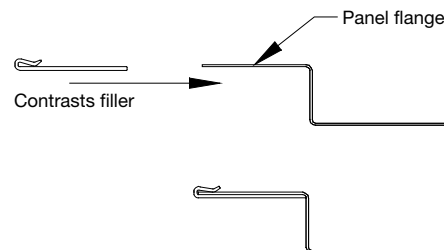

3.23 Optional Panel End Caps

Panel end caps can be used when the panel end is not covered by a moulding. This may occur at a ceiling penetration or custom perimeter treatment, such as a floating installation. Panel end must be cut square and clean. Press the cap into the panel until it is flush with the end.

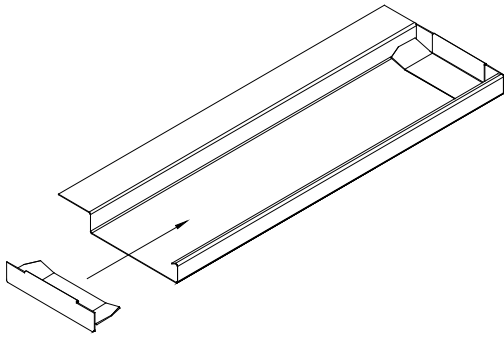

4.3.2 Perpendicular to the F-Plank Panels

When a curved ceiling abuts a wall it is usual to float the ceiling. The F-Plank can be fitted with end caps.

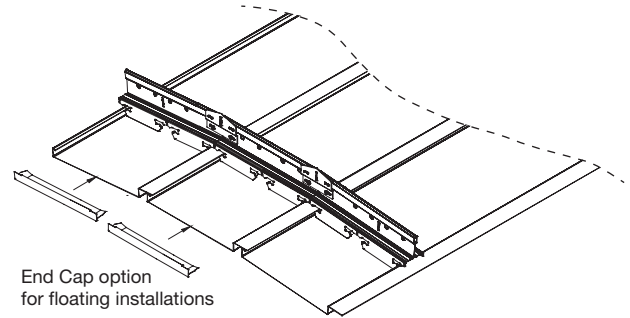

4. CURVED INSTALLATIONS

METALWORKS F-Plank panels can be installed to create a curved or vaulted ceiling. To do this, first install Armstrong drywall grid at the radius or shape of the desired ceiling from the job plan. Follow the Drywall Grid Technical Guide for hanging curved ceilings. Copies are available from your Armstrong Office or from armstrongceilings.com.au.

Curved METALWORKS F-Plank systems use the Flex Carrier (item BP5498M).

4.1 Flex Carrier

A METALWORKS F-Plank curved system is actually a faceted application with a 100mm, 200mm or 300mm facet depending on the panel width. To curve or facet the flex carrier, snip the small vertical section between panel tabs.

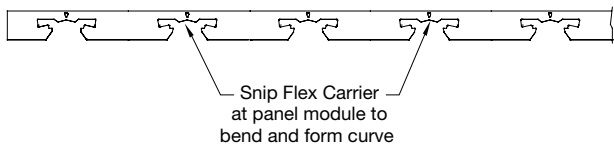

4.2 Attach the flex carrier to the drywall grid with a typical framing screw. Start installing the carrier at one side, flex the carrier as needed, attaching the midpoint of the carrier to the curved drywall grid system. Install the F-Plank panels in the same way as described in Section 3.

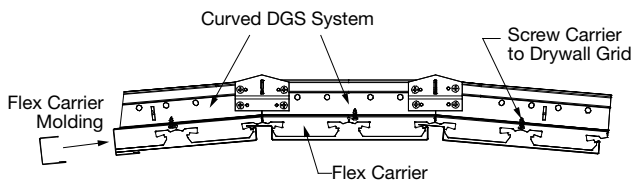

4.3 Flex Carrier Moulding is used at the perimeter of curved F-Plank metal installations.

4.3.1 Perpendicular to the Carrier

The moulding can be attached to the flex carrier when installed perpendicular to the flex carrier. Use pressure springs to keep the panel tight in the flex carrier moulding.

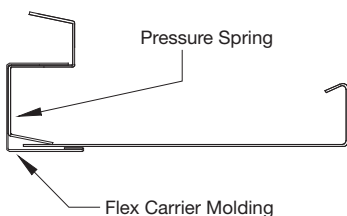

4.4 Wall Installations

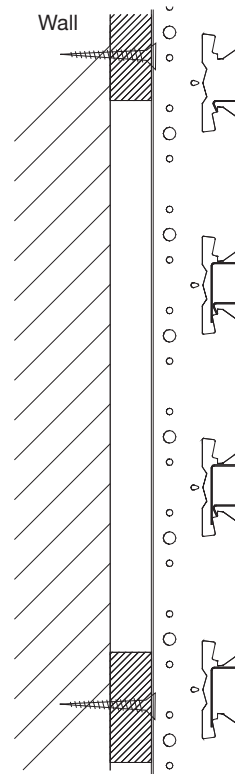

4.4.1 METALWORKS F-Plank can only be installed on the wall horizontally. Install noggin horizontally, securing them to wall studs or a solid wall with appropriate fasteners for the substrate. Spacing between furring should not be more than 600mm. The first furring strip at the bottom should be elevated from the floor by no more than 150mm. The last noggin at the top should be within 150mm from the existing ceiling.

4.4.2 Install carrier directly to noggin 1200mm on center. The first and last carrier must be within 200mm from the end to control plank twist. Install the planks with the flange facing down starting at the bottom going up.

4.4.3 Install speed clip at plank joints. Speed clip installation will be blind because of proximity to the wall structure.

4.4.4 Wall-to-wall installations can use standard carrier moulding. If not wall-to-wall, use end caps on planks but all other components may be in line of sight.

4.5 Curved Ceiling-to-Wall Transitions

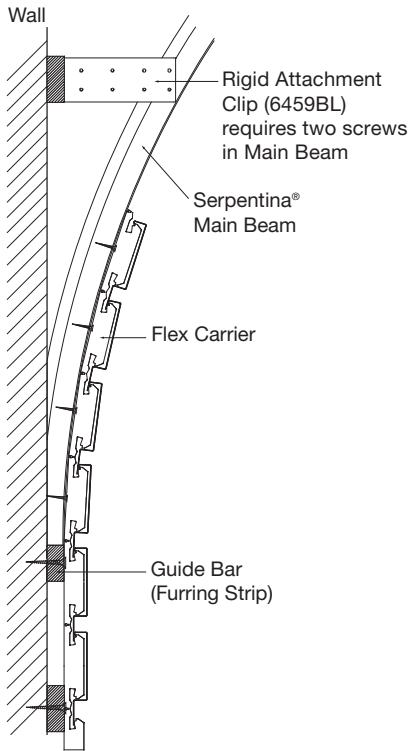

4.5.1 METALWORKS F-Plank can be installed to create a curved transition from ceiling to wall by using (only for 100mm wide planks) faceting drywall grid main beams.

Radius minimums:

300mm plank – 1800mm radius

200mm plank – 1200mm radius

100mm plank – 600mm radius

See section 4. CURVED INSTALLATIONS for instructions on how to facet drywall grid main beams.

4.5.2 Once you have your desired radius in DGS main beam, fit the bottom of it to sit flush with the guide bar (furring strip). Use Rigid Attachment Clips or other rigid kicker (by others) to stabilize curved piece. Install hanger to deck 150mm from wall, then 600mm spacing going up the transition. Attach the flex carrier to the curved main beam every 300mm using appropriate fasteners per substrate. Install planks with flange down starting from the bottom.

4.5.3 If a curved transition is installed, use flex carrier for horizontal ceiling installation.

4.5.4 METALWORKS F-Plank curved transitions are single wall only.

5. PANEL PENETRATIONS

5.1 Penetrations through F-Plank metal panels are made using typical metal working equipment. Hole saws work well for sprinklers. Tin snips can be used for larger openings. All penetrations should be fitted with escutcheons that conceal the cut panel edges.

5.2 Panels are not to be used to support the weight of ceiling mounted hardware. These items are to be supported directly from the overhead structure.

6. ACCESS PANELS

6.1 Access panels must be installed at each location where entry through the ceiling is required; plan size and location carefully to ensure that all above ceiling equipment requiring service is reachable.

6.2 Make sure that a carrier is installed not more than 300mm from each end of the openings. If sections of carrier must be added, they should extend at least one full plank width beyond the sides of the openings.

6.3 Frame the opening with sections of “E” Wall Moulding carefully mitered and cut to match the size of the opening.

6.4 Fabricate a second frame for the infill panel. Size this frame 12mm smaller, in both directions, than the ceiling opening.

6.5 Cut lengths of panel to fill the door making sure that they will line up with the panels in the field of the ceiling.

6.6 Attach the panel sections to lengths of standard carrier cut to fit in the completed frame. Carriers are to be not more than 300mm from the ends of the access panel and not more than 1200mm on center.

6.7 Assemble the frame around panel sections and secure.

6.8 Attach two support rails the top side of the infill panel. These may be fabricated from sections of standard carrier or from steel stud. The rails should run parallel to the length of the door and extend at least 300mm beyond the frame at both ends.

6.9 Attach 6mm thick foam gasket to the edges of the door. Hold the gasket about 12mm up from the face of the moulding.

6.10 Lay the access door in place.

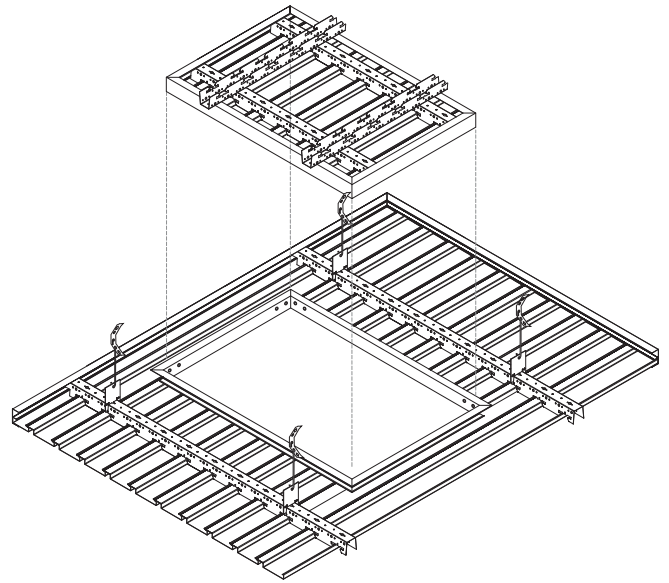



MORE INFORMATION

For complete technical information, detail drawings, CAD design assistance, installation information and many other technical services, call your local Armstrong office.

For the latest product selection and specification data, visit armstrongceilings.com.au

All Trademarks are owned by AWI Licensing Company

Armstrong, the Global Leader in Acoustic Ceilings

NSW

Armstrong World Industries Pty. Ltd.
99 Derby Street,
Silverwater NSW 2128
Telephone (02) 9748 1588
Facsimile (02) 9748 8449

QLD/NT

Armstrong World Industries Pty. Ltd.
6 Barrinia Street,
Slacks Creek QLD 4127
Telephone (07) 3809 5565
Facsimile (07) 3809 5507

WA

Ceiling Manufacturers of Australia Pty. Ltd.
5 Irvine Street,
Bayswater WA 6053
Telephone (08) 9271 0777
Facsimile (08) 9272 2801

VIC/TAS

Armstrong World Industries Pty. Ltd.
29-39 Mills Road,
Braeside VIC 3195
Telephone (03) 9580 9633
Facsimile (03) 9587 5139

SA

Total Building Systems Pty. Ltd.
160 Grand Junction Road,
Blair Athol SA 5084
Telephone (08) 7325 7555
Facsimile (08) 7325 7566

New Zealand

Forman Building Systems Ltd.
PO Box 12349,
Penrose, Auckland
Telephone 64-9-276 4000
Facsimile 64-9-276 4141

www.armstrongceilings.com.au

Printed on Zanders Mega Recycled paper
©2015 Armstrong World Industries Pty Ltd.
AWP0615

Inspiring Great Spaces™

Armstrong®

CEILING SYSTEMS

METALWORKS™ F-PLANK SYSTEM COMPONENTS

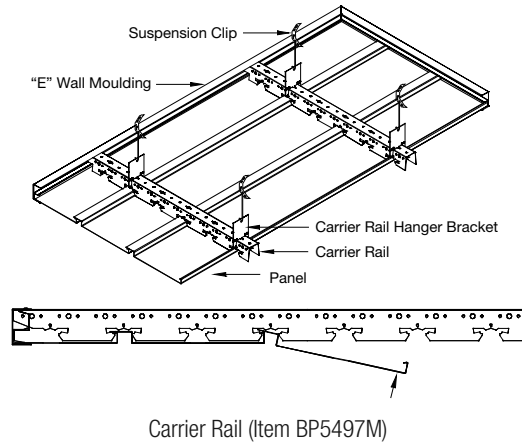

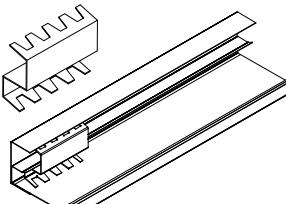
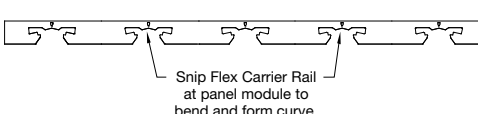
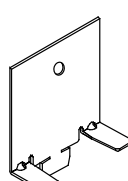
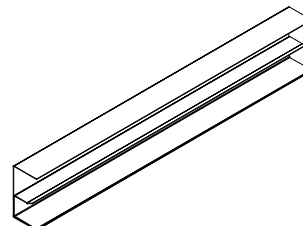
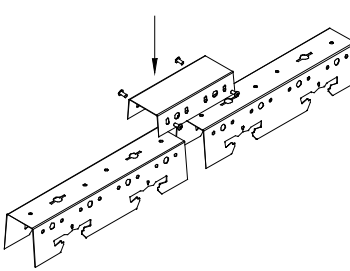
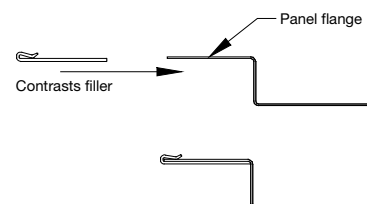
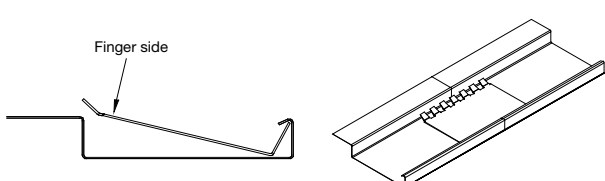
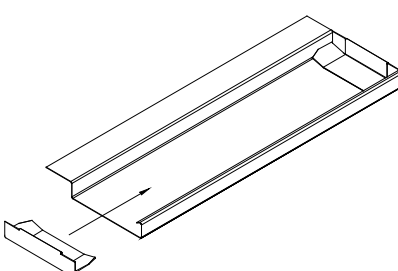
 <p>Pressure Spring (Item BP5576M) with "E" Wall Moulding (Item BP6543_*)</p>	 <p>Flex Carrier Rail (item BP5498M)</p>	 <p>Carrier Hanger (Item BP5580M)</p>
 <p>"E" Wall Moulding (Item BP6543_*)</p>	 <p>Carrier Rail Joiner (Item BP5499M)</p>	 <p>Contrasts Filler Strip (Black - Item BP5494M)</p>
 <p>Panel Splice Plate 100mm (item BP5495M) 200mm (item BP5496M) 300mm (item BP5575M)</p>		 <p>Panel End Cap 100mm (item BP6545_*) 200mm (item BP6546_*) 300mm (item BP6547_*)</p>

* When specifying or ordering, include the appropriate two letter colour suffix to match panel.