

InvisAcoustics

Under Slab Ceiling Panels

Armstrong[®]
CEILING SOLUTIONS



INVISACOUSTICS

INVISACOUSTICS: Under Slab Ceiling Panels

InvisAcoustics by Armstrong, delivers much needed sound absorption for “exposed structure” commercial spaces.

Benefits

- High acoustical performance (NRC up to 0.85) for a quieter, less reverberant space
- Cost effective panel and mounting grid
- Speed of installation
- Direct fix grid application
- Simple pre-engineered mounting grid with perimeter trims
- Available in Traffic White, Black and special RAL and Wood Effects colours on request
- Standard 1200x600mm panels for easy handling
- Prefinished durable scrim and beveled edge
- No slab preparation or use of expensive & messy adhesives
- Total system depth of 50mm (20mm thick panels)
- 30mm air gap (between slab and back of panel) to accommodate electrical cables

Typical Applications

- Any interior space where there is an exposed structure
- Auditoriums, Classrooms and lecture theatres
- Bars, restaurants and other hospitality areas
- Commercial Offices • Specialty retail • Airport lounges

Wood Effects: Refer to back page for selection considerations and the “SOUNDSCAPES Finishes” Brochure for larger images.



American Oak

Curly Birch

Walnut

Casuarina

Western Red Cedar

Jarrah

Spotted Gum

Kwila

RAL Colours Available (sample only). For a full list of RAL Colours, refer to the “SOUNDSCAPES Finishes” Brochure.



Installation and Suspension System

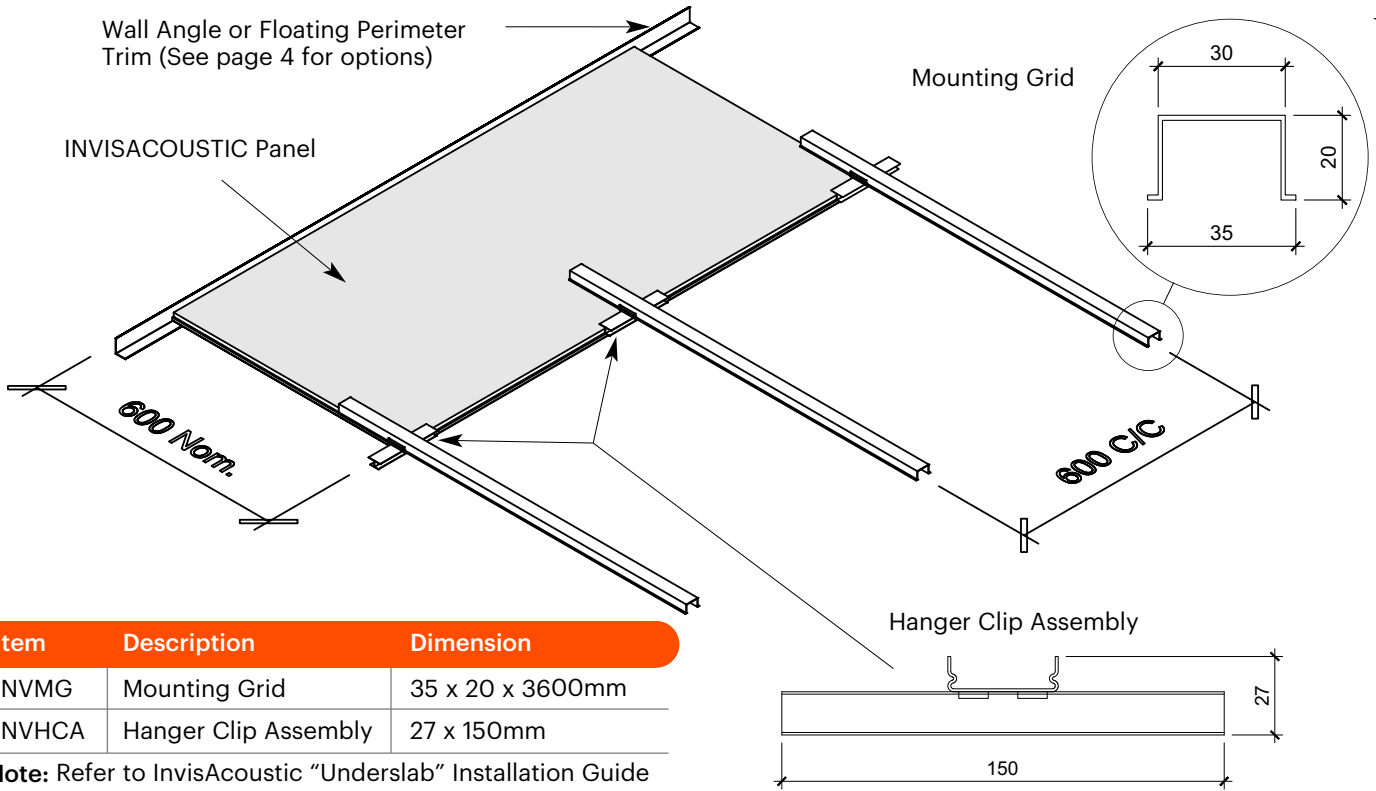

Item	Description	Dimension
INVMG	Mounting Grid	35 x 20 x 3600mm
INVHCA	Hanger Clip Assembly	27 x 150mm

Note: Refer to InvisAcoustic "Underslab" Installation Guide for additional details

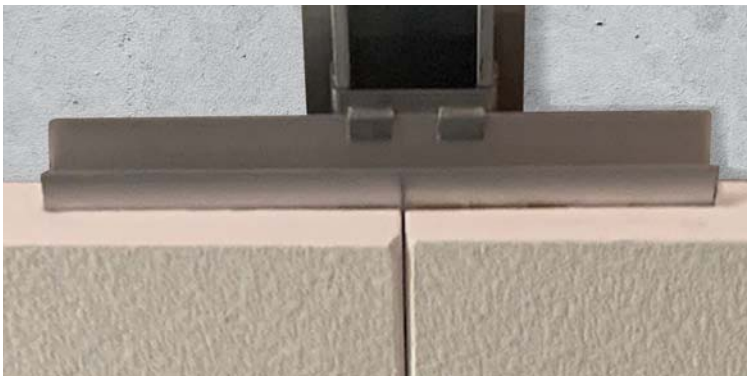

Performance



Sound Absorption
EN ISO 354 & EN
ISO 11654

INVISACOUSTICS panels can significantly reduce background noise levels and reverberation times within spaces and enhance speech intelligibility. The glasswool substrate provides high levels of absorption with panels being applied as a continuous "invisible" ceiling, or installed as a flexible array; or as a 'discrete' absorber when installed as separate decorative elements.

Acoustical Data – Sound Absorption (NRC)

Panel Thickness	NRC
• INVISACOUSTICS – 20mm	0.75
• INVISACOUSTICS – 30mm	0.85

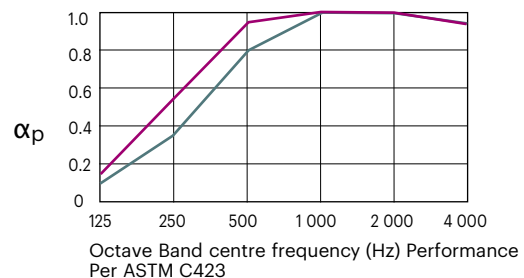

* Average of 500-4000Hz, laboratory measurements with units suspended at 30mm (depth) in accordance with EN ISO 354:2003.



Note: INVISACOUSTICS panels are produced from 20mm or 30mm thick OPTRA glasswool.

The acoustical performance of a space is primarily determined by its volume and how much sound absorbing material is present. This includes the quantity and size of the INVISACOUSTICS panels being installed. Acoustical engineers can calculate the room acoustical performance or contact your Armstrong Technical Representative for additional performance information and details on our Reverberation Time and Acoustical Calculator.

Physical Data

Specification:	Armstrong INVISACOUSTICS "underslab", glass wool acoustic ceiling panels and Aluminium direct fix mounting grid system		
Material:	OPTRA Glasswool substrate		
Surface Finish:	Durable scrim to face, with factory-applied acrylic paint or Wood Effects image		
Edge Detail:	K4C4 and painted to match panel face		
Colours:	  		
Refer to "Wood Effects and RAL Colour Palette Chart" for details	Traffic White RAL9016	Wood Effects	RAL colours available upon request

Item nr.	Dimensions (mm)	Pieces / carton	Weight
INV 061220	600 x 1200 x 20	4pcs/ctn	2.3 kg/panel
INV 061230	600 x 1200 x 30	4pcs/ctn	3.5 kg/panel

Other sizes on request.

Perimeter Solutions

Item	Description	Dimension
ALSW1	Heavy Duty Wall Angle	25 x 35 x 3600mm
CT20	"C" Perimeter Trim (20mm Panel)	25 x 45 x 3600mm
CT30	"C" Perimeter Trim (30mm Panel)	25 x 55 x 3600mm





Wood Effects selection considerations

1. Wood Effects finishes above are indicative only and may vary from the actual product.
2. Wood Effects finishes are not recommended in areas where there are high levels of critical or glancing light.
3. Wood Effects finishes closely simulate a natural timber appearance and a variation can be expected in the wood pattern and shade between adjacent panels.

 Humidity Resistance 95%

 Conforms with NCC Spec. C1.10 as tested to AS 5637.1:2015 – Group 1, and ISO 5660 – Group 1 – S

 Thermal Insulation (R-Value) 0.47 m²K/W

 **80%**
Recycled Content

 **90%**
Light Reflectance

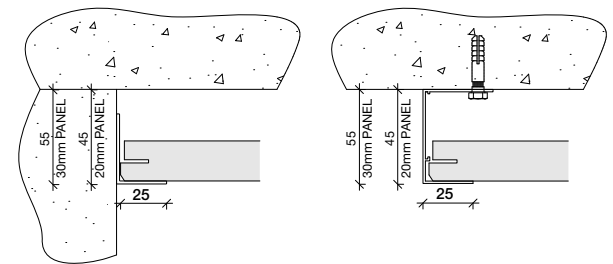
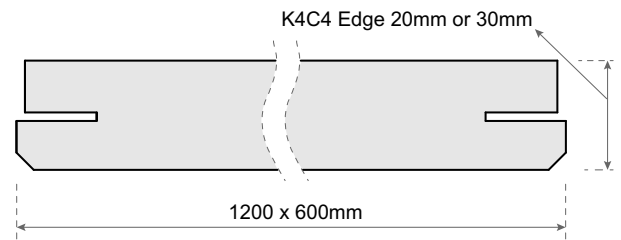

Contact us

NSW/ACT

Armstrong Ceiling Solutions (Australia) Pty. Ltd.
Unit 4, 1 Basalt Road, Pemulwuy NSW 2145
Telephone (02) 9748 1588

VIC/TAS

Armstrong Ceiling Solutions (Australia) Pty. Ltd.
Unit 1, 88 Henderson Road, Rowville VIC 3178
Telephone (03) 8706 4000

QLD / NT

Armstrong Ceiling Solutions (Australia) Pty. Ltd.
6 Barrinia Street, Slacks Creek QLD 4127
Telephone (07) 3809 5565

SA

Total Building Systems Pty. Ltd.
160 Grand Junction Road, Blair Athol SA 5084
Telephone (08) 7325 7555

WA

Ceiling Manufacturers of Australia Pty. Ltd.
3 Irvine Street, Bayswater WA 6053
Telephone (08) 9271 0777

New Zealand

Forman Building Systems Ltd.
27B Smales Road, East Tamaki, Auckland 2013
Telephone 64-9-276 4000

